

6

5

4

3

2

1

REVISIONS

CHANGE ORDER	LTR	DESCRIPTION	DATE	APPROVED
CR	1	QPCL-0150 (24V) WAS QPCL-0151 (12V)	02/27/12	

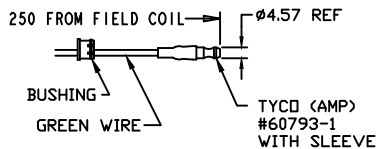

TERMINAL LEAD DETAIL

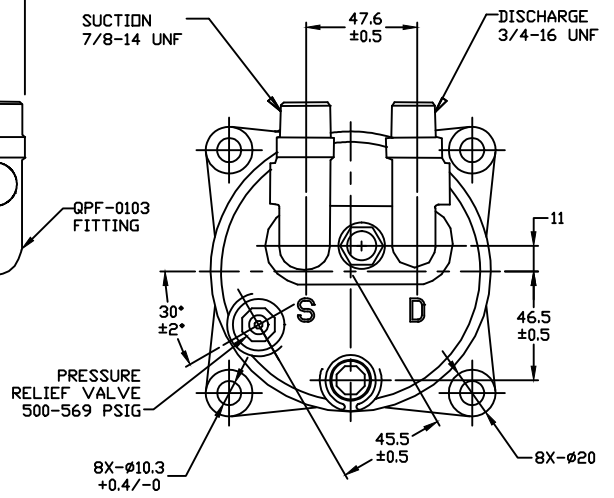
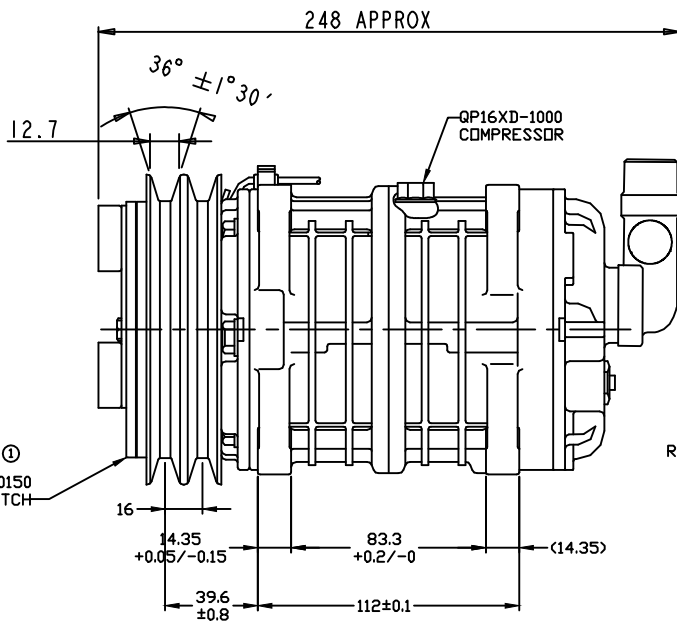
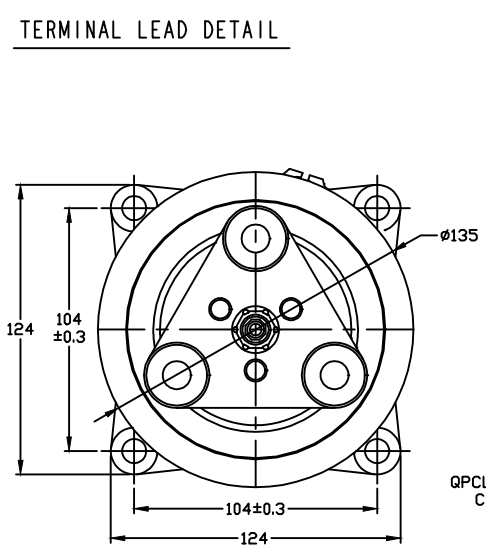

- CLUTCH SPECIFICATIONS:**
- VOLTAGE..... 24 VDC ①
 - BELT..... A2
 - STATIC TORQUE
INITIAL..... 35 Nm (3.5 Kgf)
AFTER BURNISHING..... 49 Nm (5 Kgf)
 - MAX POWER CONSUMPTION..... 45W @ 25°C
 - ROTATION DIRECTION..... CW OR CCW
 - WEIGHT..... 2.5 Kg

- COMPRESSOR SPECIFICATIONS:**
- MODEL..... QP16
 - NUMBER OF CYLINDERS..... 6
 - BORE X STROKE..... 36 X 26.7 mm
 - DISPLACEMENT..... 162.9 cm³/REV
 - SPEED RANGE..... 700 - 6000 RPM
 - ROTATION DIRECTION..... CW OR CCW
 - REFRIGERANT..... R-134A or R-404a
 - LUBRICANT..... -NO OIL- SHIP DRY
 - WEIGHT..... 4.5 Kg

UNLESS OTHERWISE SPECIFIED DIMENSIONS ARE IN MM. INTERPRET DIM AND TOL PER ASME Y14.5M - 1994		CAD GENERATED DRAWING, DO NOT MANUALLY UPDATE		MANUFACTURING, L.L.C. DECATUR, ILLINOIS USA	
THIRD ANGLE PROJECTION	DRAWN GLB	DATE 02/04/10	TITLE COMPRESSOR ASSEMBLY QP16HD -NO OIL-V-3/4 7/8 A2 135mm 24V 3-EYE ①		
	CHECKED		SIZE A	CODE IDENT NO	DWG NO - REV QP16XD-1243_1
	APPROVED		SCALE NONE		
FINISH	ENG APPVL		SHEET 1 OF 1		

6

5

4

3

2

1