

6

5

4

3

2

1

REVISIONS

CHANGE ORDER	LTR	DESCRIPTION	DATE	APPROVED

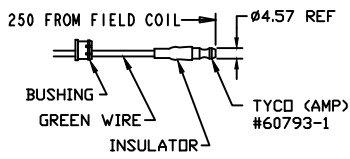

TERMINAL LEAD DETAIL

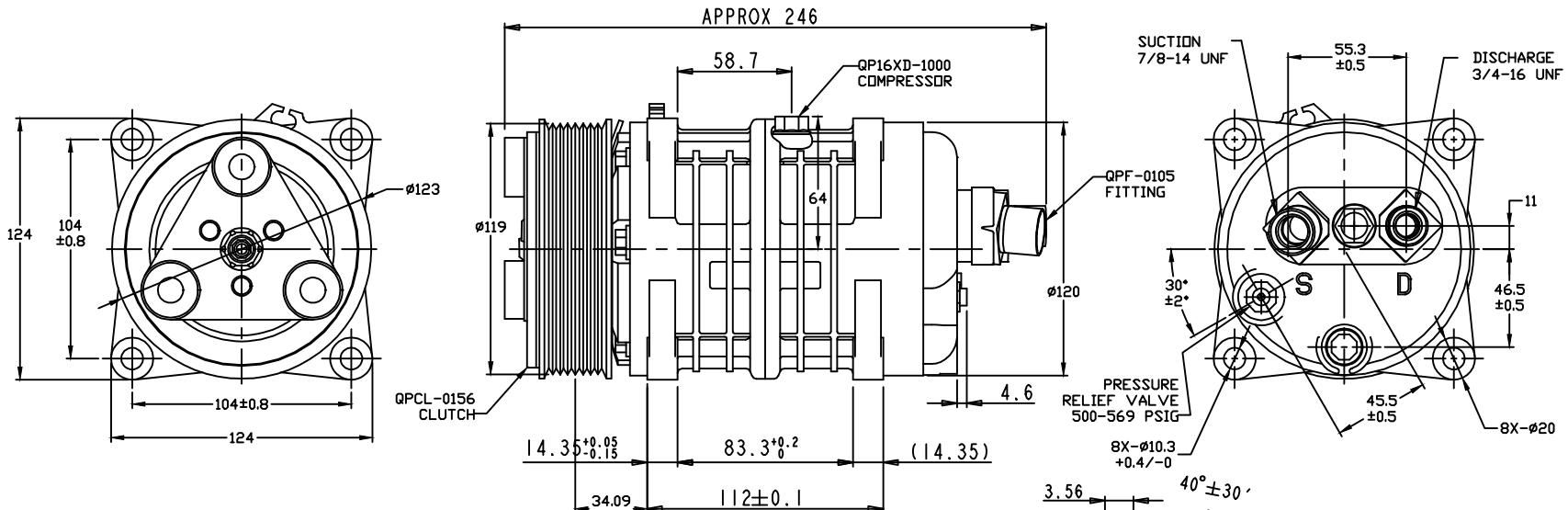

- CLUTCH SPECIFICATIONS:**
- VOLTAGE..... 24 VDC
 - BELT..... PV8
 - STATIC TORQUE
INITIAL..... 35 Nm (3.5 Kgfm)
AFTER BURNISHING..... 49 Nm (5 Kgfm)
 - MAX POWER CONSUMPTION..... 45W @ 25°C
 - ROTATION DIRECTION..... CW OR CCW
 - WEIGHT..... 2.30 Kg

- COMPRESSOR SPECIFICATIONS:**
- MODEL..... QP16HD
 - NUMBER OF CYLINDERS..... 6
 - BORE X STROKE..... 36 X 26.7 mm
 - DISPLACEMENT..... 162.9 cm³/REV
 - SPEED RANGE..... 700 - 6000 RPM
 - ROTATION DIRECTION..... CW OR CCW
 - REFRIGERANT..... R-134a or R-404a
 - LUBRICANT..... NO OIL -SHIP DRY-
 - WEIGHT..... 4.5 Kg

UNLESS OTHERWISE SPECIFIED DIMENSIONS ARE IN MM. INTERPRET DIM AND TOL PER ASME Y14.5M - 1994	CAD GENERATED DRAWING, DO NOT MANUALLY UPDATE		 MANUFACTURING, L.L.C. DECATUR, ILLINOIS USA
	THIRD ANGLE PROJECTION	DRAWN GLB DATE 03/29/11	
	CHECKED		SIZE A CODE IDENT NO DWG NO - REV
	APPROVED		QP16XD-1634
FINISH	ENG APPVL		SCALE NONE SHEET 1 OF 1

6

5

4

3

2

1